

FCW

Fan coils wall-mount installation



- Versions with internal 2 or 3-way valve
- Compact dimensions



DESCRIPTION

Fan coil model for wall-mount installations, whose elegance and reduced dimensions make it aesthetically pleasing; this terminal is thus suitable for applications in residential or light commercial sectors.

To respond to the various system requirements, the product is configurable and available with or without (2- or 3-way) valve, as well as with or without control board, which ensures compatibility with various system requirements.

Fan coils without control board must be necessarily combined with an external control device.

VERSIONS

- 2V** Internal 2-way valve and microprocessor control
- 2VN** Internal 2-way valve without microprocessor control
- 3V** Internal 3-way valve and microprocessor control
- 3VN** Internal 3-way valve without microprocessor control
- VL** Without internal valve but with microprocessor control
- VLN** Without internal valve and microprocessor control

FEATURES

Case

- Aesthetically styled with flat panel:
- Microprocessor control

- Air flow louvered fins with horizontal adjustment facility
- Colors pure white pantone GRIS 1C RAL 9010.

Ventilation group

Consisting of a tangential fan, especially quiet and directly coupled to the motor shaft.

Three-speed cross flow fan.

Heat exchanger coil

With copper pipes and aluminium louvers, the main coil has female gas hydraulic connections and is fitted with air vents.

The coil is not suitable for use in corrosive atmosphere or in environments where aluminium may be subject to corrosion.

Air filter

Fan coils are fitted with air filters easy to remove and clean.

Control

The versions with microprocessor control have:

- Timer for programming switch-off or switch-on (TLW2 and PFW2)
- Program for operation in automatic, cooling, heating, ventilation and air ionising mode (TLW2 and PFW2)
- Night time Well-being Program (TLW2)
- Automatic season change (TLW2 and PFW2)
- Automatic re-start after power cut.

ACCESSORIES

For models with control board installed

FCW_2V, 3V, VL it is mandatory to select among the user interfaces designed for the FCW series (TLW2 or PFW2)

PFW3: This accessory is essential for fan coil operation (as an alternative to TLW3). The PFW3 wired panel is supplied separately from the fan coil. It is used to set the main device operating parameters, and is essential for setting the Modbus address of the unit (handy only if you want to command the unit via the RS-485 port).

TLW3: Mandatory accessory. Infrared remote control with liquid crystal display for controlling all unit functions. The remote control is delivered separately from the fan coil; with a single remote control it is possible to control more than one fan coil. The remote control is equipped with a support that allows you to hang it on the wall, from which it can be operated without having to be removed.

TLW2



PFW2



ACCESSORIES COMPATIBILITY

VMF system

For models without control board installed

FCW_2VN, 3VN, VLN a user interface must be mounted outside the fan coil, using either a visible or a recessed wall-mount installation.

To make the selection please refer to the "control panels" or "VMF system sheet" where you will find comprehensive information on this topic.

VMF-E0X: Thermostat to be secured to the side of the fan coil, fitted as standard with an air probe and a water probe.

VMF-E19: Thermostat to be secured to the side of the fan coil, fitted as standard with an air probe and a water probe.

VMF-E4DX: Wall-mounted user interface. Grey front panel PANTONE 425C (METAL).

VMF-E4X: Wall-mounted user interface. Light grey front panel PANTONE COOL GRAY 1C.

Control panels and dedicated accessories

Model	Ver	22	32	42	52
PFW2	2V,3V,VL	•	•	•	•
TLW2 (1)	2V,3V,VL	•	•	•	•

(1) Accessory is required for operating the fan coil as an alternative to the wired remote control panel PFW2. mandatory accessory for versions with controller FCW_2V, FCW_3V, FCW_VL.

PERFORMANCE SPECIFICATIONS

2-pipe

	FCW22VL			FCW32VL			FCW42VL			FCW52VL			FCW222V			FCW223V					
	1	2	3	1	2	3	1	2	3	1	2	3	1	2	3	1	2	3			
	L	M	H	L	M	H	L	M	H	L	M	H	L	M	H	L	M	H			
Heating performance 70 °C / 60 °C (1)																					
Heating capacity	kW			2,85	3,66	4,29	3,73	4,51	5,24	6,44	7,84	8,56	8,20	13,06	15,28	2,35	3,02	4,03	2,35	3,02	4,03
Water flow rate system side	l/h			250	321	377	328	396	460	565	688	751	718	1145	1339	206	265	354	206	265	354
Pressure drop system side	kPa			4	6	9	9	12	16	16	22	26	10	23	30	9	14	24	9	14	24
Heating performance 45 °C / 40 °C (2)																					
Heating capacity	kW			1,42	1,82	2,14	1,85	2,24	2,61	3,21	3,90	4,26	4,10	6,50	7,60	1,17	1,50	2,00	1,17	1,50	2,00
Water flow rate system side	l/h			246	316	371	322	390	453	556	677	739	712	1129	1320	203	261	348	203	261	348
Pressure drop system side	kPa			4	6	8	9	12	16	15	22	25	10	22	29	9	14	24	9	14	24
Cooling performance 7 °C / 12 °C (3)																					
Cooling capacity	kW			1,37	1,74	2,05	1,78	2,15	2,50	3,07	3,74	4,08	4,40	6,50	7,45	1,10	1,45	1,90	1,10	1,45	1,90
Sensible cooling capacity	kW			1,16	1,47	1,73	1,51	1,82	2,04	2,59	3,10	3,47	3,30	5,05	5,80	0,92	1,20	1,55	0,92	1,20	1,55
Water flow rate system side	l/h			236	299	353	306	370	430	528	643	702	755	1115	1278	189	249	327	189	249	327
Pressure drop system side	kPa			5	7	9	8	11	15	15	21	26	12	24	30	9	14	23	9	14	23
Fan																					
Type	type			Tangential			Tangential			Tangential			Tangential			Tangential					
Fan motor	type			On-Off			On-Off			On-Off			On-Off			On-Off					
Number	no.			1			1			1			1			1					
Air flow rate	m ³ /h			280	340	389	330	400	446	476	602	684	592	945	1179	270	330	380	270	330	380
Input power	W			23	24	27	22	23	27	31	41	48	38	55	75	23	24	27	23	24	27
Sound data fan coils (4)																					
Sound power level	dB(A)			42,0	48,0	53,0	42,0	48,0	53,0	44,0	49,0	54,0	44,0	54,0	60,0	42,0	48,0	53,0	42,0	48,0	53,0
Sound pressure	dB(A)			34,0	39,5	44,5	34,0	39,5	44,5	35,5	40,5	45,5	35,5	45,5	51,5	34,0	39,5	44,5	34,0	39,5	44,5
Diameter hydraulic fittings																					
Main coil	Ø			1/2"			1/2"			1/2"			1/2"			1/2"					
Power supply																					
Power supply				230V~50Hz			230V~50Hz			230V~50Hz			230V~50Hz			230V~50Hz					

	FCW322V			FCW323V			FCW422V			FCW423V			FCW522V			FCW523V					
	1	2	3	1	2	3	1	2	3	1	2	3	1	2	3	1	2	3			
	L	M	H	L	M	H	L	M	H	L	M	H	L	M	H	L	M	H			
Heating performance 70 °C / 60 °C (1)																					
Heating capacity	kW			3,25	4,36	5,03	3,25	4,36	5,03	6,29	7,23	7,97	6,29	7,23	7,97	8,04	11,80	14,00	8,04	11,80	14,00
Water flow rate system side	l/h			286	383	442	286	383	442	552	635	699	552	635	699	704	1034	1227	704	1034	1227
Pressure drop system side	kPa			13	22	29	13	22	29	21	27	32	21	27	32	10	21	28	10	21	28
Heating performance 45 °C / 40 °C (2)																					
Heating capacity	kW			1,62	2,17	2,50	1,62	2,17	2,50	3,13	3,60	3,96	3,13	3,60	3,96	4,00	5,90	7,00	4,00	5,90	7,00
Water flow rate system side	l/h			281	377	434	281	377	434	543	624	688	543	624	688	695	1025	1216	695	1025	1216
Pressure drop system side	kPa			13	22	29	13	22	29	20	26	31	20	26	31	11	22	30	11	22	30
Cooling performance 7 °C / 12 °C (3)																					
Cooling capacity	kW			1,55	2,08	2,40	1,55	2,08	2,40	3,00	3,45	3,80	3,00	3,45	3,80	4,00	6,00	7,00	4,00	6,00	7,00
Sensible cooling capacity	kW			1,28	1,68	1,97	1,28	1,68	1,97	2,01	2,50	2,85	2,01	2,50	2,85	2,85	4,50	5,30	2,85	4,50	5,30
Water flow rate system side	l/h			267	358	413	267	358	413	516	593	654	516	593	654	686	1030	1201	686	1030	1201
Pressure drop system side	kPa			13	22	29	13	22	29	21	27	32	21	27	32	11	23	30	11	23	30
Fan																					
Type	type			Tangential			Tangential			Tangential			Tangential			Tangential					
Fan motor	type			On-Off			On-Off			On-Off			On-Off			On-Off					
Number	no.			1			1			1			1			1					
Air flow rate	m ³ /h			320	390	440	320	390	440	370	470	540	370	470	540	535	859	1082	535	859	1082
Input power	W			22	23	27	22	23	27	31	41	48	31	41	48	38	55	75	38	55	75
Sound data fan coils (4)																					
Sound power level	dB(A)			42,0	48,0	53,0	42,0	48,0	53,0	44,0	49,0	54,0	44,0	49,0	54,0	44,0	54,0	60,0	44,0	54,0	60,0
Sound pressure	dB(A)			34,0	39,5	44,5	34,0	39,5	44,5	35,5	40,5	45,5	35,5	40,5	45,5	35,5	45,5	51,5	35,5	45,5	51,5
Diameter hydraulic fittings																					
Main coil	Ø			1/2"			1/2"			1/2"			1/2"			1/2"					
Power supply																					
Power supply				230V~50Hz			230V~50Hz			230V~50Hz			230V~50Hz			230V~50Hz					

(1) Room air temperature 20 °C d.b.; Water (in/out) 70 °C/60 °C

(2) Room air temperature 20 °C d.b.; Water (in/out) 45 °C/40 °C; EUROVENT

(3) Room air temperature 27 °C d.b./19 °C w.b.; Water (in/out) 7 °C/12 °C; EUROVENT

(4) Aermec determines sound power values on the basis of measurements made in accordance with UNI EN 16583:15, as required for Eurovent certification.

DIMENSIONS

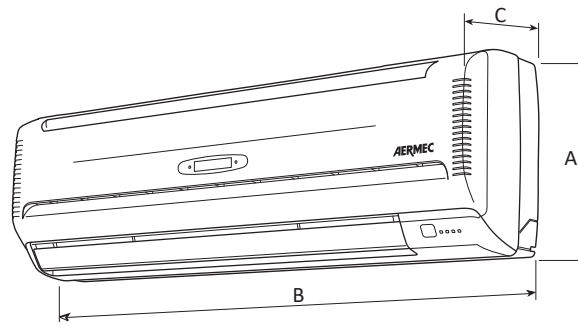

		FCW22VL	FCW32VL	FCW42VL	FCW52VL	FCW222V	FCW223V
Dimensions and weights							
A	mm	298	305	360	365	298	298
B	mm	880	990	1170	1450	880	880
C	mm	205	210	220	230	205	205
Weight empty	kg	9	10	19	28	9	9

		FCW322V	FCW323V	FCW422V	FCW423V	FCW522V	FCW523V
Dimensions and weights							
A	mm	305	305	360	360	365	365
B	mm	990	990	1170	1170	1450	1450
C	mm	210	210	220	220	230	230
Weight empty	kg	10	10	19	19	28	28

Aermec reserves the right to make any modifications deemed necessary.
All data is subject to change without notice. Aermec does not assume responsibility or liability for errors or omissions.

Aermec S.p.A.
Via Roma, 996 - 37040 Bevilacqua (VR) - Italia
Tel. 0442633111 - Telefax 044293577
www.aermec.com

FCWI

Fan coils wall-mount installation



- Versions with internal 2 or 3-way valve
- Electric saving equal to 50% with respect to a fan coil with 3-speed motor
- Total comfort: reduced temperature and humidity oscillations
- Fully silent operation



DESCRIPTION

Fan coil model for wall-mount installations, whose elegance and reduced dimensions make it aesthetically pleasing; this terminal is thus suitable for applications in residential or light commercial sectors. The product is configurable and available with or without (2- or 3-way) valve which ensures compatibility with various system requirements.

VERSIONS

- 2V** Internal 2-way valve and microprocessor control
- 3V** Internal 3-way valve and microprocessor control
- VL** Without internal valve but with microprocessor control

FEATURES

Case

- Aesthetically styled with flat panel:
- Air flow louvered fins with horizontal adjustment facility
- Motorised deflector louvers that can be activated by remote control TLW3 for vertical orientation of the outlet air with steps fixed positions and continuous oscillation
- Colors pure white pantone GRIS 1C RAL 9010.

Ventilation group

Consisting of a tangential fan, especially quiet and directly coupled to the motor shaft.
Brushless motor with continuous speed variation 0-100%.

Inverter motor allows precise adaptation to the real indoor environment requirements without temperature oscillations. This lowers noise and generates a better response to heat loads and a higher stability in the desired temperature inside the room. The high efficiency even with low speed, makes it possible to reduce power consumption (more than 50% less than fan coils with traditional motors).

Heat exchanger coil

With copper pipes and aluminium louvers, the main coil has female gas hydraulic connections and is fitted with air vents. The coil is not suitable for use in corrosive atmosphere or in environments where aluminium may be subject to corrosion.

Air filter

Fan coils are fitted with air filters easy to remove and clean.

Control

- The versions with microprocessor control have:
- Timer for programming switch-off or switch-on (TLW3/ PFW3)
 - Program for operation in automatic, cooling, heating, ventilation and air ionising mode (TLW3/ PFW3)
 - Night time Well-being Program (TLW3/ PFW3)
 - Automatic season change (TLW3/ PFW3)
 - Automatic re-start after power cut.
 - Option of contact on the terminal board which enables to obtain a signal (230V, max 1A) with which to control the system pump.

ACCESSORIES

For models with control board installed

FCWI_2V, 3V, VL it is mandatory to select among the user interfaces designed for the FCWI series (TLW3 o PFW3)

PFW3: This accessory is essential for fan coil operation (as an alternative to TLW3). The PFW3 wired panel is supplied separately from the fan coil. It is used to set the main device operating parameters, and is essential for setting the Modbus address of the unit (handy only if you want to command the unit via the RS-485 port).

TLW3: Mandatory accessory. Infrared remote control with liquid crystal display for controlling all unit functions. The remote control is delivered separately from the fan coil; with a single remote control it is possible

to control more than one fan coil. The remote control is equipped with a support that allows you to hang it on the wall, from which it can be operated without having to be removed.

TLW3



PFW3



ACCESSORIES COMPATIBILITY

Control panels and dedicated accessories

Model	Ver	22	32	42	52
PFW3 (1)	2V,3V,VL	•	•	•	•
TLW3 (1)	2V,3V,VL	•	•	•	•

(1) Compulsory accessory.

PERFORMANCE SPECIFICATIONS

2-pipe

	FCWI22VL			FCWI32VL			FCWI42VL			FCWI52VL			FCWI222V			FCWI223V					
	1	2	3	1	2	3	1	2	3	1	2	3	1	2	3	1	2	3			
	L	M	H	L	M	H	L	M	H	L	M	H	L	M	H	L	M	H			
Heating performance 70 °C / 60 °C (1)																					
Heating capacity	kW			2,85	3,66	4,29	3,73	4,51	5,24	6,44	7,84	8,56	8,20	13,06	15,28	2,35	3,02	4,03	2,35	3,02	4,03
Water flow rate system side	l/h			250	321	377	328	396	460	565	688	751	718	1145	1339	206	265	354	206	265	354
Pressure drop system side	kPa			4	6	9	9	12	16	16	22	26	10	23	30	9	14	24	9	14	24
Heating performance 45 °C / 40 °C (2)																					
Heating capacity	kW			1,42	1,82	2,14	1,85	2,24	2,61	3,21	3,90	4,26	4,10	6,50	7,60	1,17	1,50	2,00	1,17	1,50	2,00
Water flow rate system side	l/h			246	316	371	322	390	453	556	677	739	712	1129	1320	203	261	348	203	261	348
Pressure drop system side	kPa			4	6	8	9	12	16	15	22	25	10	22	29	9	14	24	9	14	24
Cooling performance 7 °C / 12 °C (3)																					
Cooling capacity	kW			1,37	1,74	2,05	1,78	2,15	2,50	3,07	3,74	4,08	4,40	6,50	7,45	1,10	1,45	1,90	1,10	1,45	1,90
Sensible cooling capacity	kW			1,16	1,47	1,73	1,51	1,82	2,04	2,59	3,10	3,47	3,30	5,05	5,80	0,92	1,20	1,55	0,92	1,20	1,55
Water flow rate system side	l/h			236	299	353	306	370	430	528	643	702	755	1115	1278	189	249	327	189	249	327
Pressure drop system side	kPa			5	7	9	8	11	15	15	21	26	12	24	30	9	14	23	9	14	23
Fan																					
Type	type			Tangential																	
Fan motor	type			Inverter																	
Number	no.			1			1			1			1			1			1		
Air flow rate	m ³ /h			280	340	389	330	400	446	476	602	684	592	945	1179	270	330	380	270	330	380
Input power	W			23	24	27	22	23	27	31	41	48	38	55	75	13	17	22	23	24	27
Fan coil sound data (4)																					
Sound power level	dB(A)			42,0	48,0	53,0	42,0	48,0	53,0	44,0	49,0	54,0	44,0	54,0	60,0	42,0	48,0	53,0	42,0	48,0	53,0
Sound pressure	dB(A)			34,0	39,5	44,5	34,0	39,5	44,5	35,5	40,5	45,5	35,5	45,5	51,5	34,0	39,5	44,5	34,0	39,5	44,5
Diametre hydraulic fittings																					
Main coil	∅			1/2"																	
Power supply																					
Power supply	230V~50Hz																				

	FCWI322V			FCWI323V			FCWI422V			FCWI423V			FCWI522V			FCWI523V					
	1	2	3	1	2	3	1	2	3	1	2	3	1	2	3	1	2	3			
	L	M	H	L	M	H	L	M	H	L	M	H	L	M	H	L	M	H			
Heating performance 70 °C / 60 °C (1)																					
Heating capacity	kW			3,25	4,36	5,03	3,25	4,36	5,03	6,29	7,23	7,97	6,29	7,23	7,97	8,04	11,80	14,00	8,04	11,80	14,00
Water flow rate system side	l/h			286	383	442	286	383	442	552	635	699	552	635	699	704	1034	1227	704	1034	1227
Pressure drop system side	kPa			13	22	29	13	22	29	21	27	32	21	27	32	10	21	28	10	21	28
Heating performance 45 °C / 40 °C (2)																					
Heating capacity	kW			1,62	2,17	2,50	1,62	2,17	2,50	3,13	3,60	3,96	3,13	3,60	3,96	4,00	5,90	7,00	4,00	5,90	7,00
Water flow rate system side	l/h			281	377	434	281	377	434	543	624	688	543	624	688	695	1025	1216	695	1025	1216
Pressure drop system side	kPa			13	22	29	13	22	29	20	26	31	20	26	31	11	22	30	11	22	30
Cooling performance 7 °C / 12 °C (3)																					
Cooling capacity	kW			1,55	2,08	2,40	1,55	2,08	2,40	3,00	3,45	3,80	3,00	3,45	3,80	4,00	6,00	7,00	4,00	6,00	7,00
Sensible cooling capacity	kW			1,28	1,68	1,97	1,28	1,68	1,97	2,01	2,50	2,85	2,01	2,50	2,85	2,85	4,50	5,30	2,85	4,50	5,30
Water flow rate system side	l/h			267	358	413	267	358	413	516	593	654	516	593	654	686	1030	1201	686	1030	1201
Pressure drop system side	kPa			13	22	29	13	22	29	21	27	32	21	27	32	11	23	30	11	23	30
Fan																					
Type	type			Tangential																	
Fan motor	type			Inverter																	
Number	no.			1			1			1			1			1			1		
Air flow rate	m ³ /h			320	390	440	320	390	440	370	470	540	370	470	540	535	859	1082	535	859	1082
Input power	W			22	23	27	22	23	27	31	41	48	31	41	48	38	55	75	38	55	75
Fan coil sound data (4)																					
Sound power level	dB(A)			42,0	48,0	53,0	42,0	48,0	53,0	44,0	49,0	54,0	44,0	49,0	54,0	44,0	54,0	60,0	44,0	54,0	60,0
Sound pressure	dB(A)			34,0	39,5	44,5	34,0	39,5	44,5	35,5	40,5	45,5	35,5	40,5	45,5	35,5	45,5	51,5	35,5	45,5	51,5
Diametre hydraulic fittings																					
Main coil	Ø			1/2"																	
Power supply																					
Power supply	230V~50Hz																				

(1) Room air temperature 20 °C d.b.; Water (in/out) 70 °C/60 °C

(2) Room air temperature 20 °C d.b.; Water (in/out) 45 °C/40 °C; EUROVENT

(3) Room air temperature 27 °C d.b./19 °C w.b.; Water (in/out) 7 °C/12 °C; EUROVENT

(4) Aermec determines the sound power value on the basis of measurements taken in accordance with standard UNI EN 16583:15, respecting the Eurovent certification.

DIMENSIONS

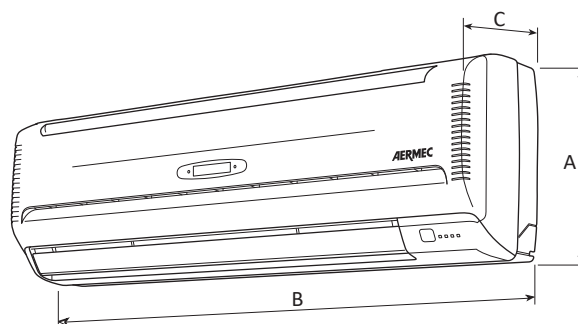

		FCWI22VL	FCWI32VL	FCWI42VL	FCWI52VL	FCWI222V	FCWI223V
Dimensions and weights							
A	mm	298	305	360	365	298	298
B	mm	880	990	1170	1450	880	880
C	mm	205	210	220	230	205	205
Weight empty	kg	9	10	19	28	9	9
		FCWI322V	FCWI323V	FCWI422V	FCWI423V	FCWI522V	FCWI523V
Dimensions and weights							
A	mm	305	305	360	360	365	365
B	mm	990	990	1170	1170	1450	1450
C	mm	210	210	220	220	230	230
Weight empty	kg	10	10	19	19	28	28

Aermec reserves the right to make any modifications deemed necessary.
All data is subject to change without notice. Aermec does not assume responsibility or liability for errors or omissions.

Aermec S.p.A.

Via Roma, 996 - 37040 Bevilacqua (VR) - Italia
Tel. 0442633111 - Telefax 044293577
www.aermec.com